

Masoneilan® 35002 Series Camflex® II Rotary Control Valves

Specification Data

CF5000

03/06

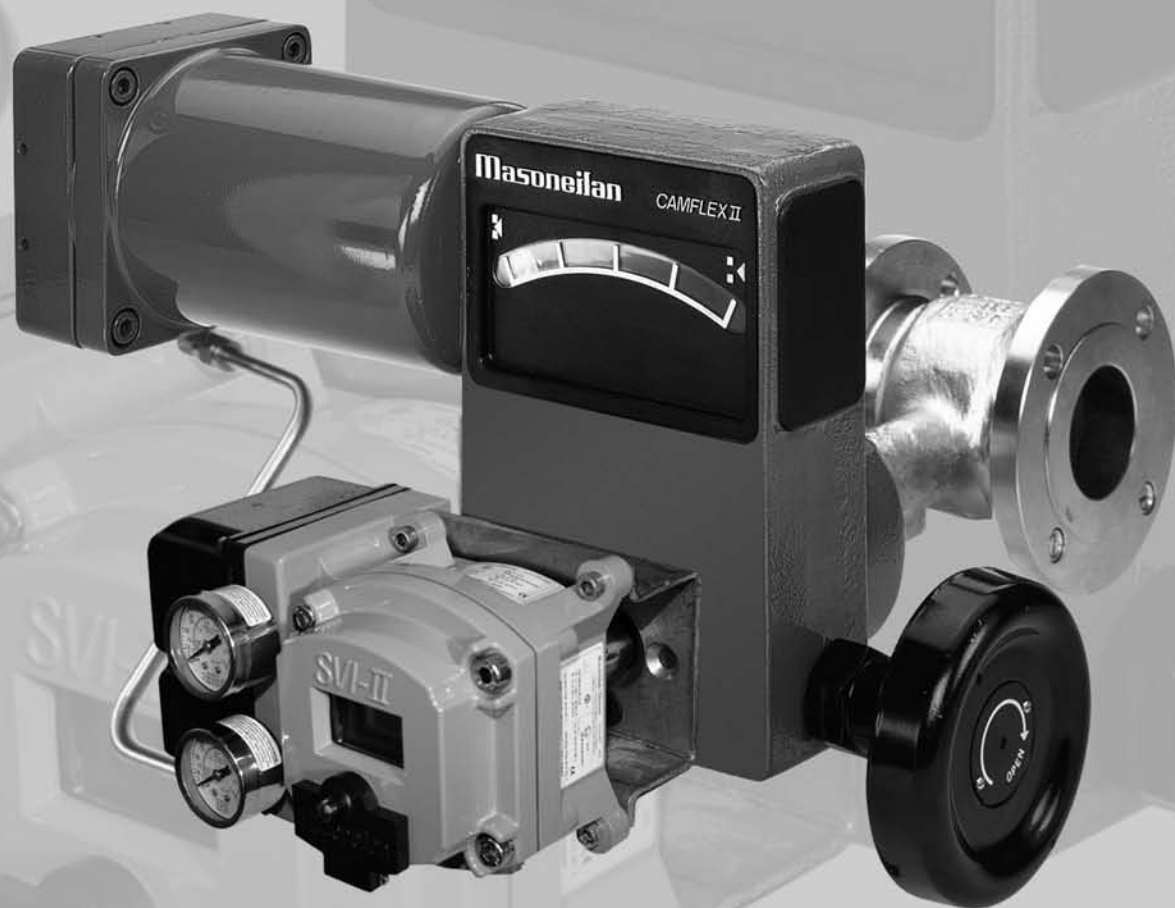

**Rugged, All-Purpose
Rotary Control Valves**



Table of Contents

Features	2
Numbering System	3
Actuator Mounting Guide.....	4
General Data	5-6
Flow Coefficients/Critical Flow Factor	6
C_v and F_L vs Travel	7-8
Materials of Construction.....	9-12
Dimensions and Weights.....	13-14

Features

The Camflex® II is a heavy duty automatic throttling control valve which incorporates the following features:

- Flangeless body rating is a rugged ANSI Class 600.
- Heavy duty guide lugs assure quick, positive alignment during installation.
- Flanged version available 1" through 12" (25mm through 300mm) in 150 or 300 ANSI and 1" through 8" (25mm through 200mm) in 600 ANSI.
- Separable Bonnet design available.
- Straight through flow pattern provides greater flow capacities.
- Standard integral extension bonnet allows for a wide range of fluid temperature applications (-320°F to 750°F), (-195°C to 399°C).
- The unique self-aligning eccentric rotating plug provides tight shut off and low dynamic forces.

- A large variety of reduced trim options are available in all sizes.
- The triple, over-sized bearing system provides exceptional plug shaft guiding.
- Shouldered shaft design.
- Optional patented differential velocity device (DVD) separates compressible flowstreams into a high velocity core and a low velocity envelope flowstream. Provides up to 18dBA noise attenuation.
- Optional alloy constructions are available.
- Powerful, low profile spring diaphragm actuator guarantees positive "fail-safe" action.
- Splined shaft and actuator linkages, combined with low friction techniques, assure minimum deadband and hysteresis.
- Large, highly visible valve position indicator.
- Totally enclosed actuator linkage (purge option available).

Trade names noted throughout are for reference only. Masoneilan reserves the right to supply trade named material or its equivalent.

Numbering System

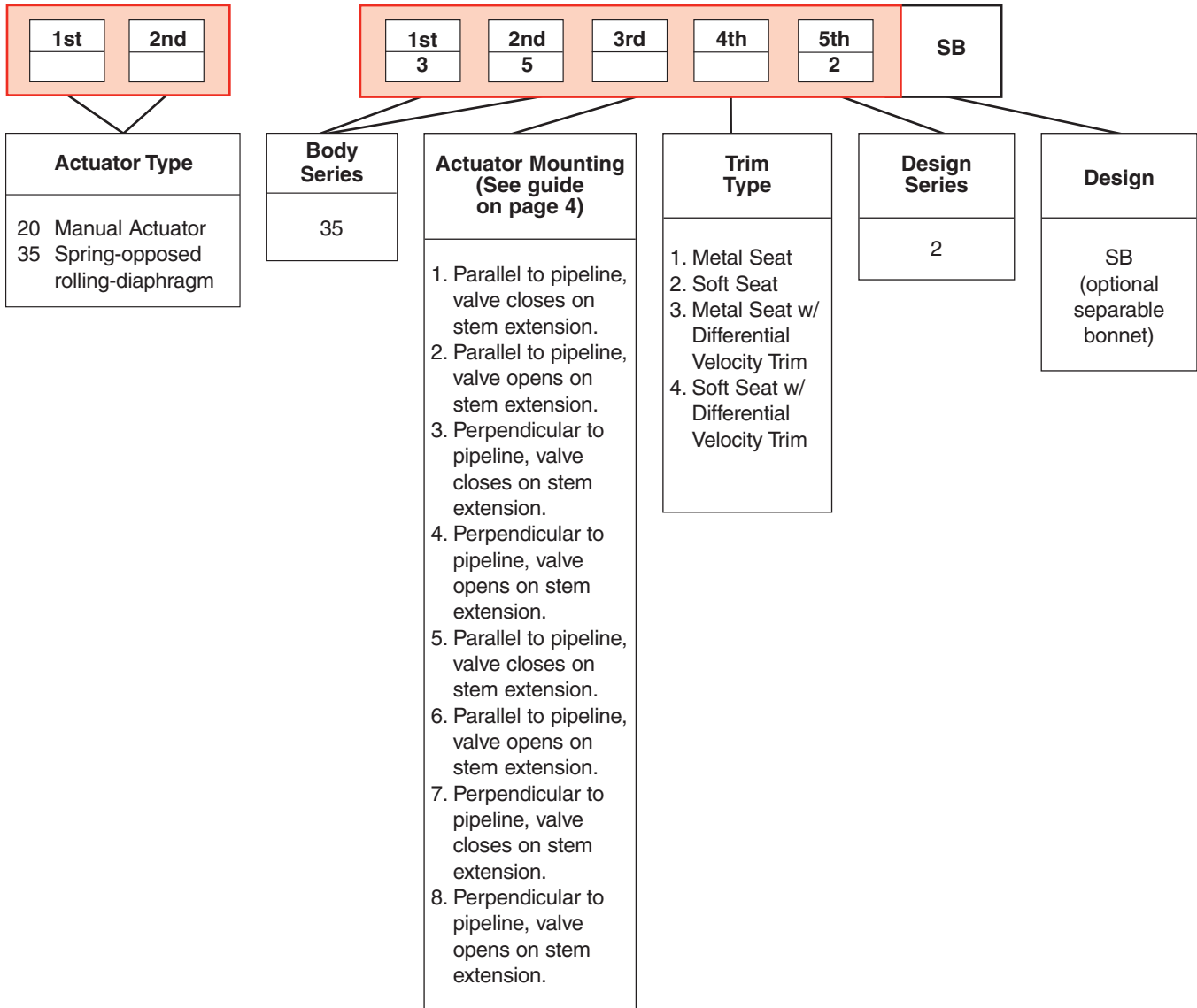

Actuator Mounting Guide

CAMFLEX II VALVES (Mounted On Horizontal Pipeline)

3 5 - 3 5 . 0 2

Actuator Position in Relation to Valve Body
Numbering System : 1 to 8

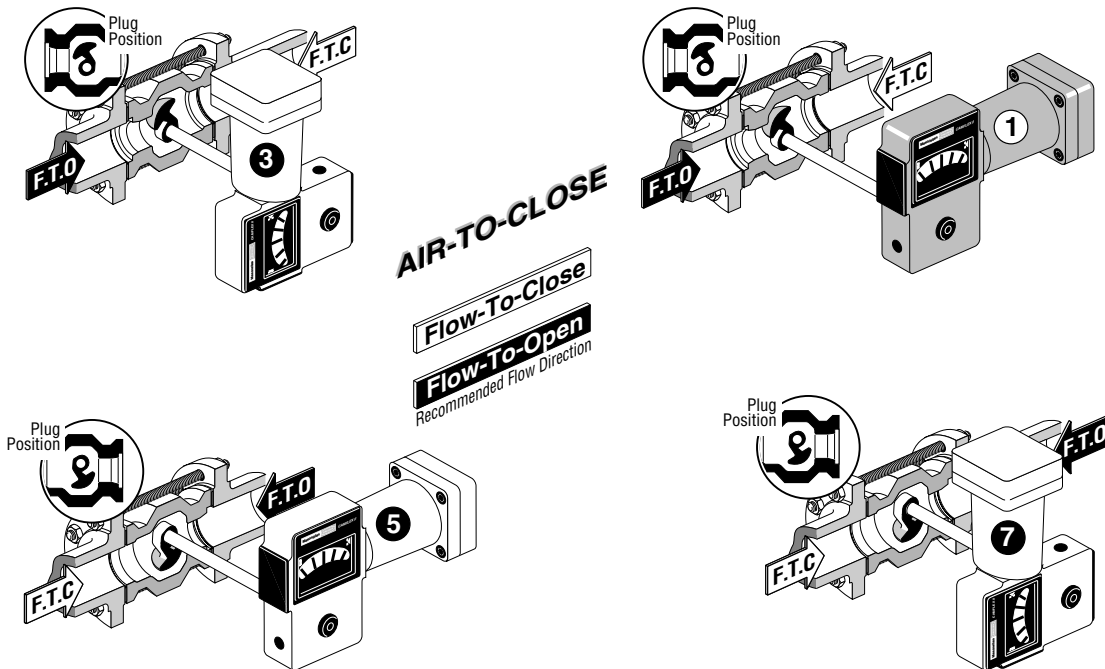
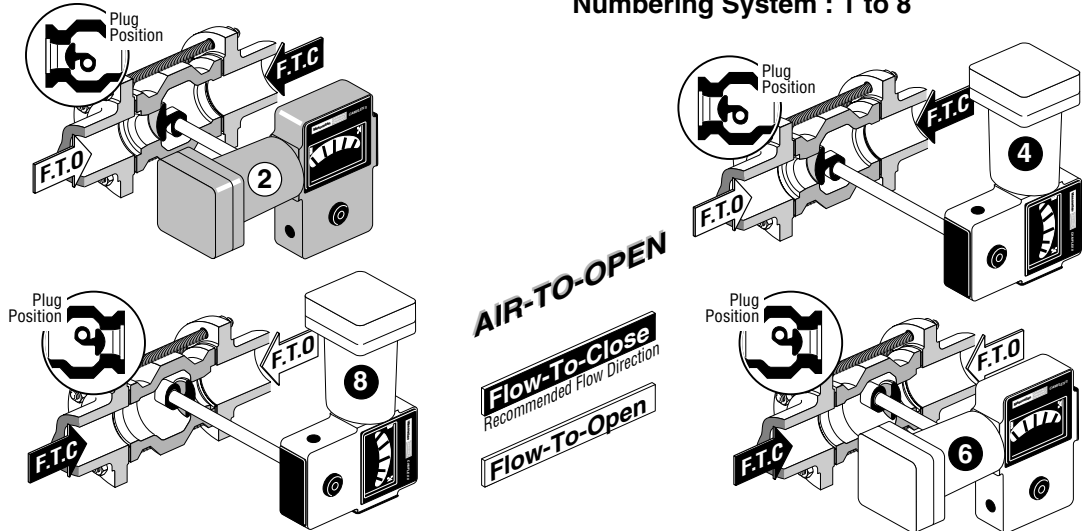

Notes:

1. It is recommended that the actuator always be mounted as shown above. For other positions, consult local sales office.
2. Installation is assumed to be in horizontal pipeline for orientation of airset and other accessories unless specified on order.
3. Action and orientation field reversible without additional parts. See Instruction EF5000.
4. Operating efficiencies may vary depending on valve configuration.
5. The above schematic does not reflect every possible body/actuator orientation, but should serve as an effective guide.

General Data

Body

Type

- cast with integral bonnet
- cast with separable bonnet - 1"-6" ANSI Class 300 only - optional

Flow Direction

- flow to open or flow to close
- (Differential Velocity Device trim flow to open only)

Materials

- carbon steel
- 316 stainless steel (flangeless)
- 316L stainless steel (flanged)
- Hastelloy "C" (1"-4") (DN 25-100)

Body Pressure Rating

- ANSI Class 600 (per B16.34) standard (1"-12") (DN 25-300) except for flanged construction; valve rating is limited by flange rating

End Connections

- **threaded** - NPT for ANSI Class 600 rated connections (1"-2") (DN 25-50)
- **flangeless** - clamps between ANSI Class 150, 300 or 600 rated flanges (flange rating must be specified for 8"-12" (DN 200-300) valve for locator lug drilling and tapping)
- **flanged** - bolts to ANSI Class 150 or 300 rated flanges (1"-12") (DN 25-300) ANSI Class 600 rated flanges (1"- 8") (DN 25-200)

Trim

Plug Type

- self-aligning eccentrically rotating

Materials

- 1"-2" (DN 25-100) solid Stellite No.6
- 3"-4" (DN 80 & 100) solid Stellite No.6 optional
- 3"-12" (DN 80-300) 316L stainless steel with hardfaced seating surface
- 1"-4" (DN 25-100) Hastelloy "C"

Seat Ring

- solid clamped

Materials

- 1"-12" (DN 25-300) 316 stainless steel
- 1"-4" (DN 25-100) Hastelloy "C"
- 3"-4" (DN 75 & 100) optional
- 1"-12" (DN 150-300) 316 stainless steel with hardfaced seat
- 1"-4" (DN 25-100) solid Stellite No.6 optional
- 1"-12" (DN 25-300) 316 stainless steel with PTFE insert (to 450°F), (232°C)①

Retainer

- 316 Stainless Steel

Capacity

- full area and reduced capacity in all sizes

Flow Characteristic

- standard trim - linear
- low flow trim (.036+.07 factor) - linear (requires SVI)
- differential velocity device - linear

C_V Ratio

- standard trim >100:1
- low flow trim 15:1
- differential velocity device >50:1

① Not available in .2 factor or Low Flow Trim sizes

Actuators

Spring-Opposed Rolling Diaphragm

Size

- 4½" diameter with 3½" (89mm) stroke (1"-2" valves), (DN 25-50)
- 6" diameter with 5¾" (146mm) stroke (3"-4" valves), (DN 80-100)
- 7" diameter with 7¼" (184mm) stroke (6"-12" valves), (DN 150-300)
- 9" diameter with 9" (229mm) stroke (6"-12" valves), (DN 150-300)

Range

- 7-15 psi (1"-4"), (DN 25-100)
- 7-24 psi (6"-12"), (DN 150-300) (7" diameter actuator)
- 7-24 psi (6"-12"), (DN 150-300) (9" diameter actuator, Air to Close)
- 8-25 psi (6"-12"), (DN 150-300) (9" diameter actuator, Air to Open)

Air Connection

- ¼" NPT

Yoke

- cast iron

Bearing

- sealed radial

Auxiliary Handwheel

- solid disk with locking nut
- 6¾" diameter (1"-4" valves), (DN 25-100)
- 10" diameter (6"-12" valves), (DN 150-300)

Manual Actuator

Type

- solid disk with detent anti-rotation device. Continuously connected

Sizes

- 7" (178mm) diameter (1"-2" valves), (DN 25-50)
- 8¾" (225mm) diameter (3" & 4" valves), (DN 80-100)
- 16⅞" (410mm) diameter (6"-12" valves), (DN 150-300)

Material

- aluminum

Yoke

- cast iron

Bearing

- sealed radial ball

Ratings and Connections

Valve Size		ANSI Class		
in.	DN	150	300	600
1-2	25-50	△ □ ●	△ □ ●	△ □ ●
3-12	80-300	□ ●	□ ●	□ ●

△ Threaded □ Flangeless ● RF Flanged

Note:

ANSI Class 600RF Flanged to 8" (200mm) size only. For flangeless valve sizes 8"-12", (200mm-300mm) please specify ANSI Class rating. Face to Face: ISA S75.04

General Data

Standard Spring Diaphragm Actuator Materials

Description	Material
Yoke	Cast Iron
Yoke Covers	Polycarbonate
Spring Barrel	Die Cast Aluminum
Diaphragm Case	Die Cast Aluminum
Piston	Die Cast Aluminum
Diaphragm	Buna-N with Dacron Insert
Piston Rod	303 St. St.
Clevis	St. St.
Clevis Pin	17-4 PH (H1075) St. St.
Lever	Steel With Epoxy Surface
Lever Bearing	PTFE Filament Surface Bonded to Glass Reinforced Plastic Backing
Handwheel and Locknut	Aluminum

Standard Actuator Characteristics and Travel Times

Actuator Diameter		Diaphragm Effective Area		Actuator Stroke		Travel Time (sec.)	
						Increasing Instrument Signal	Decreasing Instrument Signal
in.	mm	sq. in.	cm ²	in.	cm		
4½	11.4	14	90	3½	8.9	1.2	2.4
6	15.2	24	155	5½	14.6	3	6.3
7	17.8	36	232	7¼	18.4	7.6	9.8
9	22.9	75	483	7¼	18.4	17	24

Measured with direct positioner at 30 psi (2 bar) supply
4700A positioner with tubing size ¼ in.

Temperature/Seat Leakage

Valve Size		Seat Type	Temp. Range*		Max. Seat Leakage, ANSI FCI/70.2 Class
in.	DN		Min.	Max.	
1-12	25 to 300	Metal	-320°F* (-196°C)	+750°F (399°C)	IV
		Soft Seat**	-320°F* (-196°C)	+450°F (232°C)	VI

* For Stainless Steel Bodies Only.

**Temperature Limited by Teflon® Seal.

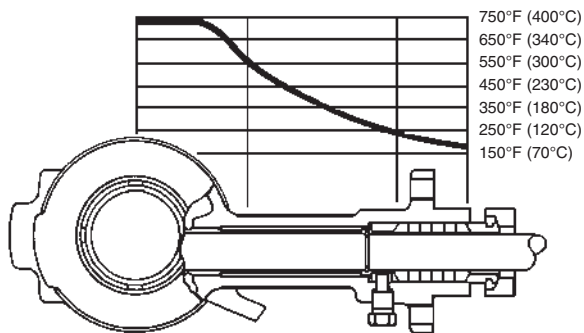

Temperature Gradient Across Standard Integral Bonnet

The ability of the Camflex valve to handle a wide range of process fluid temperatures is due to the long, integrally-cast bonnet. This affords ample radiation surface to normalize the packing temperatures.

Maximum Rated Flow Coefficients (C_v) and Critical Flow Factors (F_L) at Maximum Opening (50°)

Valve Size		Factor	Rated C _v	F _L
inches	DN			
1	25	0.036	.5	0.98
		0.07	1	0.98
		0.2	2.8	0.88
		0.4	5.6	0.88
		0.6	8.4	0.88
		1	14	0.85
		DVD	5	
1.5	40	0.4	13.2	0.88
		0.6	19.8	0.88
		1	33	0.85
		DVD	12.5	
2	50	0.4	20	0.88
		0.6	30	0.88
		1	50	0.85
		DVD	18	
3	80	0.4	54	0.88
		0.6	81	0.88
		1	135	0.85
		DVD	48	
4	100	0.4	92	0.88
		0.6	138	0.88
		1	230	0.85
		DVD	78	
6	150	0.4	200	0.88
		0.6	300	0.88
		1	500	0.85
		DVD	181	
8	200	0.4	340	0.88
		0.6	510	0.88
		1	850	0.85
		DVD	308	
10	250	0.4	520	0.88
		0.6	780	0.88
		1	1300	0.85
		DVD	486	
12	300	0.4	700	0.88
		0.6	1050	0.88
		1	1750	0.85
		DVD	684	

Note: Low flow trims (.036+.07 factor) requires use of SVI

(C_v) and (F_L) Versus Travel

Flow Direction: Flow to Close or Flow to Open

Flow Characteristics: Linear

ANSI Class: 150 through 600

Sizes: 1" through 12" (DN 25-300)

		Percent of Plug Rotation				10	20	30	40	50	60	70	80	90	100
F _L	Full Area		Flow to Open		0.96	0.93	0.91	0.89	0.88	0.87	0.87	0.86	0.86	0.85	
			Flow to Close		0.94	0.91	0.88	0.83	0.80	0.77	0.74	0.72	0.70	0.68	
	Reduced Area (.6, .4, & .2)		Flow to Open		0.96	0.93	0.91	0.89	0.88	0.88	0.88	0.88	0.88	0.88	
			Flow to Close		0.94	0.91	0.88	0.83	0.80	0.77	0.74	0.72	0.70	0.70	
Valve Size		Orifice Dia.		Act. Stem Travel		Rated C _v									
in.	DN	in.	mm	in.	mm										
1	25	.321	8.2	3.50	89	0.4	0.8	1.1	1.4	1.7	2.0	2.3	2.5	2.7	2.8
		.500	12.7	3.50	89	0.5	0.9	1.4	2.0	2.7	3.5	4.2	4.8	5.2	5.6
		.579	14.7	3.50	89	0.6	1.3	2.2	3.1	4.2	5.3	6.4	7.2	7.9	8.4
		.718	18.2	3.50	89	0.9	2.1	3.7	5.7	7.8	9.6	11.1	12.4	13.3	14
1½	40	.750	19.1	3.50	89	1.1	2.1	3.3	4.7	6.5	8.4	9.9	11.2	12.3	13.2
		.907	23.0	3.50	89	1.4	3.2	5.1	7.4	10.0	12.7	15.0	17.1	18.6	19.8
		1.125	28.6	3.50	89	2.0	5.0	8.6	13	19	22	26	29	32	33
2	50	1.000	25.4	3.50	89	1.6	3.2	5.0	7.2	9.8	12.6	15.0	17.0	18.7	20
		1.159	29.4	3.50	89	2.1	4.8	7.7	11.2	15.1	19.1	22.7	25.8	28.2	30
		1.437	36.5	3.50	89	3.1	7.5	13.3	20.5	28	34.2	39.8	44.2	47.5	50
3	80	1.500	38.1	5.75	146	4.9	9.4	14.1	20.0	26.5	33.5	39.8	45.4	50.2	54
		1.874	47.6	5.75	146	5.7	12.1	19.6	27.6	37.5	47.9	58.4	68.0	75.9	81
		2.324	59.0	5.75	146	8.8	17.7	29.8	44.5	60.7	78.3	96.2	113	127	135
4	100	2.000	50.8	5.75	146	8.4	16.1	24.0	34.1	45.1	57.1	67.8	77.4	85.6	92
		2.419	61.4	5.75	146	9.7	20.7	33.4	47.0	63.8	81.6	99.4	116	129	138
		3.000	76.2	5.75	146	15.0	30.2	50.8	75.8	104	133	164	193	216	230
6	150	3.000	76.2	7.25	184	18.2	34.9	52.2	74.1	98.0	124	147	168	186	200
		3.629	92.2	7.25	184	21.2	44.9	72.7	102	139	177	216	252	281	300
		4.500	114	7.25	184	32.7	65.7	110	165	225	290	356	419	470	500
8	200	3.797	96.4	7.25	184	22.0	44.2	71.9	107	150	196	241	283	317	340
		4.840	123	7.25	184	31.3	63.6	114	178	246	313	374	425	468	510
		6.000	152	7.25	184	42.8	111	201	316	434	542	639	725	798	850
10	250	4.746	121	7.25	184	33.7	67.6	110	164	230	300	369	432	485	520
		6.050	154	7.25	184	47.8	97.3	175	273	376	478	572	650	716	780
		7.500	191	7.25	184	65.5	170	307	483	663	828	977	1109	1221	1300
12	300	5.780	147	7.25	184	45.3	91.0	148	221	309	403	497	582	652	700
		7.460	189	7.25	184	64.4	131	235	367	506	644	769	875	964	1050
		9.250	235	7.25	184	88.1	228	414	650	893	1115	1315	1493	1644	1750

(C_v) Versus Travel

Differential Velocity Device (DVD)

Flow Direction: Flow to Open only

Flow Characteristics: Linear

ANSI Class: 150 through 600

Sizes: 1" through 12" (DN 25-300)

Percent of Plug Rotation						10	20	30	40	50	60	70	80	90	100
Valve Size		Orifice Dia.		Act. Stem Travel											
in.	DN	in.	mm	in.	mm										
1	25	0.579	14.7	3.5	89	0.52	1.04	1.88	2.62	3.23	3.76	4.22	4.58	4.84	5.00
1.5	40	0.907	23.0	3.5	89	1.30	2.60	4.69	6.54	8.06	9.41	10.5	11.4	12.1	12.5
2	50	1.159	29.4	3.5	89	1.88	3.75	6.75	9.42	11.6	13.6	15.2	16.5	17.4	18.0
3	80	1.874	47.6	5.75	146	5.00	10.0	18.0	25.1	31.0	36.1	40.5	43.9	46.4	48.0
4	100	2.419	61.4	5.75	146	8.13	16.3	29.3	40.8	50.3	58.7	65.8	71.4	75.4	78.0
6	150	3.629	92.2	7.25	184	18.9	37.7	67.9	94.7	116	136	153	166	175	181
8	200	4.84	123	7.25	184	32.1	64.2	116	161	199	232	260	282	298	308
10	250	6.05	154	7.25	184	50.6	101	182	254	313	366	410	445	470	486
12	300	7.46	189	7.25	184	71.3	143	257	358	441	515	577	626	661	684

Note: The differential velocity device is used for aerodynamic noise reduction. It must be used with .6 factor trim flow to open.

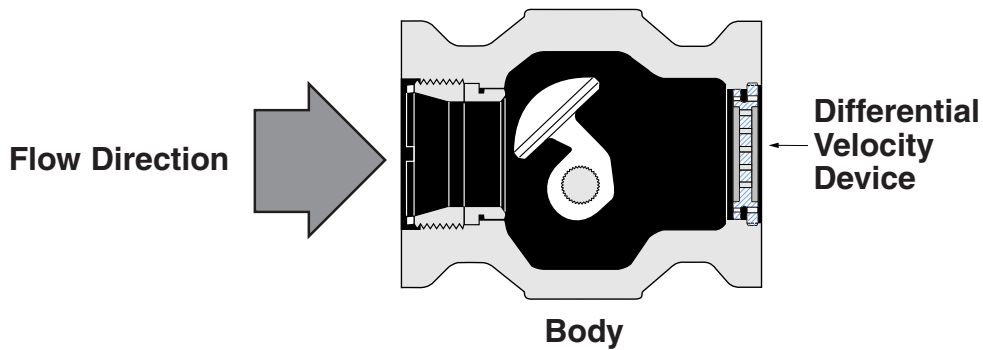

Materials of Construction

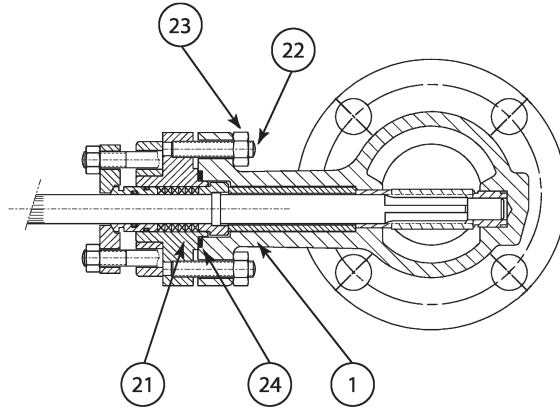

Body with Separable Bonnet

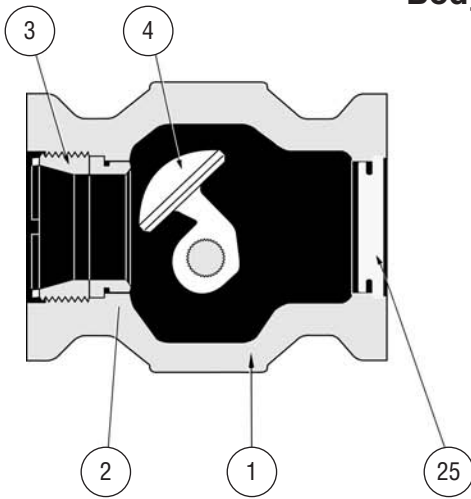

Body

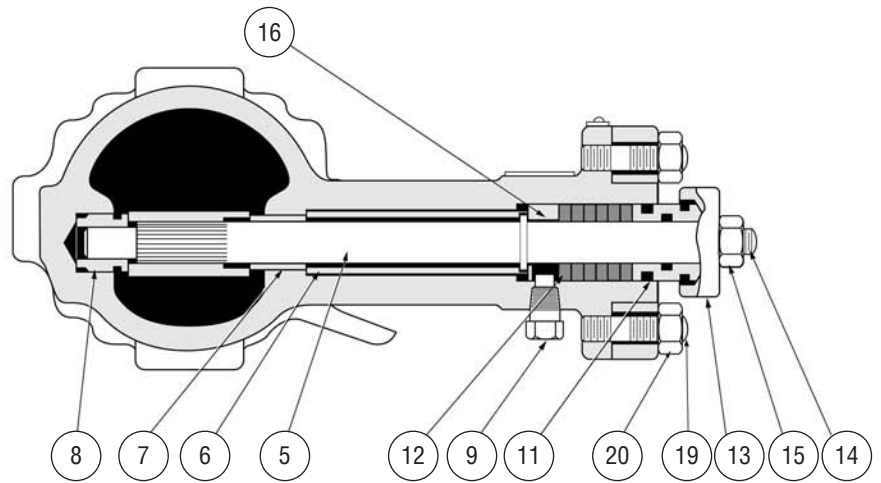

Body with Integral Bonnet

Optional Slurry Package Seal Bushings

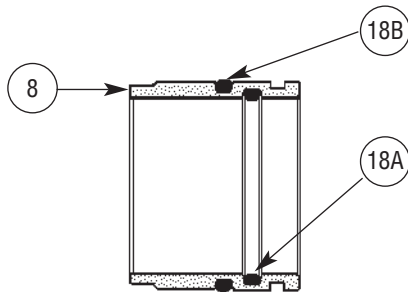

LOWER GUIDE BUSHING

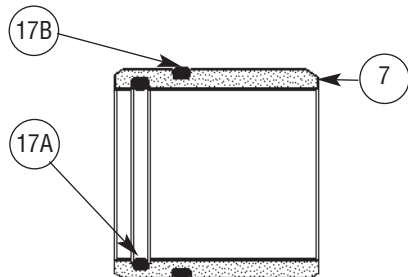

UPPER GUIDE BUSHING

Standard Camflex Packing Arrangement EF Seal

(Emission Free)

Double O-Ring Seal Packing Follower

Fugitive Emission Containment Package for Zero Leakage†

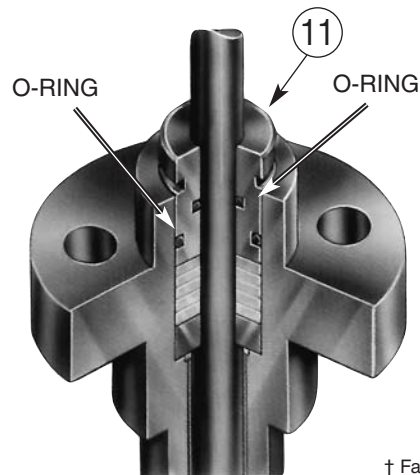

Provides long term reliable extremely low emission shaft seal performance. This economical solution to fugitive emissions won't compromise control performance, and is suitable for use in environmentally sensitive applications.

† Factory Mutual Certified Report

Materials of Construction

Carbon Steel Construction

Ref. No.	Temperature Range	-20°F	+400°F	+450°F	+750°F
		-29°C	+205°C	+232°C	+400°C
Description		Materials			
1	Body	A216 Gr WCC			
2	Seat Ring	316 St. St. ASTM A351 Gr CF8M			
		316 St. St ASTM A351 Gr CF8M + Stellite Hardfacing Optional			
3	Seat Ring Retainer	ASTM A479 TY 316 St. St. + PTFE 1" to 6" (DN 25-150)			
4	Plug	316 St. St. A351 Gr CF8M + PTFE 8" to 12" (DN 200-300)			
5	Shaft	316 St. St. ASTM A351 Gr CF8M			
6	Spacer	Solid Stellite 1" to 2" (DN 25-50)			
7	Upper Guide	316L St. St. ASTM A351 Gr CF3M + Stellite Hardfacing 3" to 12" (DN 80-300)			
8	Upper Guide + O-Ring	17-4 PH ASTM A564 Gr 630 (H1075)			
	Lower Guide	ASTM A312 TY 316			
9	Lower Guide + O-Ring	ASTM A276 TY 440C			
	Safety Pin	STELLITE No.6 + VITON			
11	Packing Follower	ASTM A276 TY 440C			
12	Packing	STELLITE No.6 + VITON			
13	Packing Flange	ASTM A479 TY 316			
14	Packing Flange Stud	ASTM A479 TY 316			
15	Packing Flange Stud Nut	Carbon Steel ASTM A105 Zinc Plated			
16	Packing Box Ring	304 St. St. ASTM A193 Gr B8			
19	Body Stud	304 St. St. ASTM A194 GR 8			
20	Body Stud Nuts	ASTM A479 TY 316			
21*	Bonnet	304 St. St. ASTM A193 Gr B8			
22*	Body / Bonnet Stud	304 St. St. ASTM A194 Gr 8			
23*	Body / Bonnet Nut	Carbon Steel A216 GR WCC			
24*	Body Gasket	ASTM A 193 GR B7 Dichromate Zinc Plated			
25	DVD Low Noise Plate	ASTM A 194 GR 2H Dichromate Zinc Plated			

* Separable Bonnet version only.

"NACE" Carbon Steel Construction

Ref. No.	Temperature Range	-20°F	+400°F	+750°F
		-29°C	+205°C	+400°C
Description		Materials		
1	Body	Carbon Steel A216 Gr WCC		
2	Seat Ring	316 St. St. ASTM A351 Gr CF8M		
		316 St. St ASTM A351 Gr CF8M + Stellite Hardfacing Optional		
3	Seat Ring Retainer	316 St. St. ASTM A351 Gr CF8M		
4	Plug	Solid Stellite 1" to 2" (DN 25-50)		
5	Shaft	316L St. St. ASTM A351 Gr CF3M + Stellite Hardfacing 3" to 12" (DN 80-300)		
6	Spacer	ASTM A479 TY 316 St. St.		
7	Upper Guide	ASTM A312 TY 316		
	Upper Guide + O-Ring	STELLITE No.6		
8	Lower Guide	STELLITE No.6 + VITON		
	Lower Guide + O-Ring	STELLITE No.6		
9	Safety Pin	STELLITE No.6 + VITON		
11	Packing Follower	ASTM A479 TY 316		
	O-Ring Packing Follower	ASTM A479 TY 316		
12	Packing	VITON		
13	Packing Flange	PTFE + KEVLAR		
14	Packing Flange Stud	Carbon Steel ASTM A105 Zinc Plated		
15	Packing Flange Stud Nut	304 St. St. ASTM A 193 GR B8		
16	Packing Box Ring	304 St. St. ASTM A194 GR 8		
19	Body Stud	ASTM A479 TY 316		
20	Body Stud Nuts	304 St. St. ASTM A193 Gr B8		
25	DVD Low Noise Plate	304 St. St. ASTM A194 Gr 8		

Note: Standard materials and processes are in accordance with the requirements of NACE specification MR0103. Applications requiring compliance to MR0175-2003 or ISO 15156 must be reviewed by Masoneilan.

Materials of Construction

Stainless Steel Construction

Ref. No.	Temperature Range	-320°F	-58°F	+400°F	+450°F	+750°F
		-196°C	-50°C	+205°C	+232°C	+400°C
Description		Materials				
1	Body	Flangeless Body 316 St. St. ASTM A351 Gr CF8M Flanged Body 316L St. St. ASTM A351 GR CF3M				
2	Seat Ring	316 St. St. ASTM A351 Gr CF8M 316 St. St ASTM A351 Gr CF8M + Stellite Hardfacing Optional				
3	Seat Ring Retainer	316 St. St. ASTM A351 Gr CF8M				
4	Plug	Solid Stellite 1" to 2" (DN 25-50) 316L St. St. ASTM A351 Gr CF3M + Stellite Hardfacing N°6 3" to 12" (DN 80-300)				
5	Shaft	316 St. St. ASTM A479 TY 316				
6	Spacer	ASTM A 312 TY 316				
7	Upper Guide	STELLITE No. 6				
	Upper Guide + O-Ring	STELLITE No. 6 + VITON				
8	Lower Guide	STELLITE No. 6				
	Lower Guide + O-Ring	STELLITE No. 6 + VITON				
9	Safety Pin	ASTM A479 TY 316				
11	Packing Follower	ASTM A582 TY 303				
	O-Ring	VITON				
12	Packing	PTFE + KEVLAR				
13	Packing Flange	ASTM A182 GR F304				
14	Packing Flange Stud	304 St. St. ASTM A193 Gr B8				
15	Packing Flange Stud Nut	304 St. St. ASTM A194 Gr 8				
16	Packing Box Ring	ASTM A479 TY 316				
19	Body Stud	304 St. St. ASTM A 193 Gr B8				
20	Body Stud Nuts	304 St. St. ASTM A194 Gr 8				
21*	Bonnet	316L St. St. ASTM A351 Gr CF3M				
22*	Body / Bonnet Stud	304 St. St. ASTM A193 GR B8 CL 2				
23*	Body / Bonnet Nut	304 St. St. ASTM A194 GR 8				
24*	Body Gasket	AISI 316L + GRAPHITE				
25	DVD Low Noise Plate	ASTM A479 TY 316				

* Separable Bonnet version only.

"NACE" Stainless Steel Construction

Ref. No.	Temperature Range	-20°F	+400°F	+750°F
		-29°C	+205°C	+400°C
Description		Materials		
1	Body	Flangeless Body 316 St. St. ASTM A351 Gr CF8M Flanged Body 316L St. St. ASTM A351 Gr CF3M		
2	Seat Ring	316 St. St. ASTM A351 Gr CF8M 316 St. St ASTM A351 Gr CF8M + Stellite Hardfacing		
3	Seat Ring Retainer	316 St. St. ASTM A351 Gr CF8M		
4	Plug	Solid Stellite 1" to 2" (DN 25-50) 316L St. St. ASTM A351 Gr CF3M + Stellite Hardfacing 3" to 12" (DN 80-300)		
5	Shaft	ASTM A479 TY 316 St. St.		
6	Spacer	ASTM A312 TY 316		
7	Upper Guide	STELLITE No. 6		
	Upper Guide + O-Ring	STELLITE No. 6 + VITON		
8	Lower Guide	STELLITE No. 6		
	Lower Guide + O-Ring	STELLITE No. 6 + VITON		
9	Safety Pin	ASTM A479 TY 316		
11	Packing Follower	ASTM A479 TY 316		
	O-Ring	VITON		
12	Packing	PTFE + KEVLAR		
13	Packing Flange	ASTM A182 GR F304		
14	Packing Flange Stud	304 St. St. ASTM A193 Gr B8		
15	Packing Flange Stud Nut	304 St. St. ASTM A194 Gr 8		
16	Packing Box Ring	ASTM A479 TY 316		
19	Body Stud	304 St. St. ASTM A 193 Gr B8		
20	Body Stud Nuts	304 St. St. ASTM A194 Gr 8		
25	DVD Low Noise Plate	ASTM A479 TY 316		

Note: Standard materials and processes are in accordance with the requirements of NACE specification MR0103. Applications requiring compliance to MR0175-2003 or ISO 15156 must be reviewed by Masoneilan.

Materials of Construction

Hastelloy "C" Construction 1" to 4"

Ref. No.	Temperature Range	-320°F	-58°F	+400°F	+750°F
		-196°C	-50°C	+205°C	+400°C
	Description	Materials			
1	Body	HASTELLOY C			
2	Seat Ring	HASTELLOY C			
		HASTELLOY C + PTFE			
3	Seat Ring Retainer	HASTELLOY C			
4	Plug	HASTELLOY C			
5	Shaft	HASTELLOY C			
6	Spacer	HASTELLOY C			
7	Upper Guide ¹	STELLITE No. 6			
	Upper Guide ¹	ALLOY 25			
	Upper Guide ¹	ULTIMET			
	Upper Guide + O-Ring ¹		STELLITE No. 6 + VITON		
8	Lower Guide ¹	STELLITE No. 6			
	Lower Guide ¹	ALLOY 25			
	Upper Guide ¹	ULTIMET			
	Lower Guide + O-Ring ¹		STELLITE No. 6 + VITON		
9	Safety Pin	HASTELLOY C			
11	Packing Follower	HASTELLOY C			
	O-Ring	VITON			
12	Packing	PTFE + KEVLAR			
13	Packing Flange	ASTM A182 Gr F304			
14	Packing Flange Stud	304 St. St. ASTM A193 Gr B8			
15	Packing Flange Stud Nut	304 St. St. ASTM A194 Gr 8			
16	Packing Box Ring	HASTELLOY C			
19	Body Stud	304 St. St. ASTM A193 Gr B8			
20	Body Stud Nuts	304 St. St. ASTM A194 Gr 8			
25	DVD Low Noise Plate	HASTELLOY C			

1. Material selection must be based on fluid properties and compatibility.

Dimensions and Weights

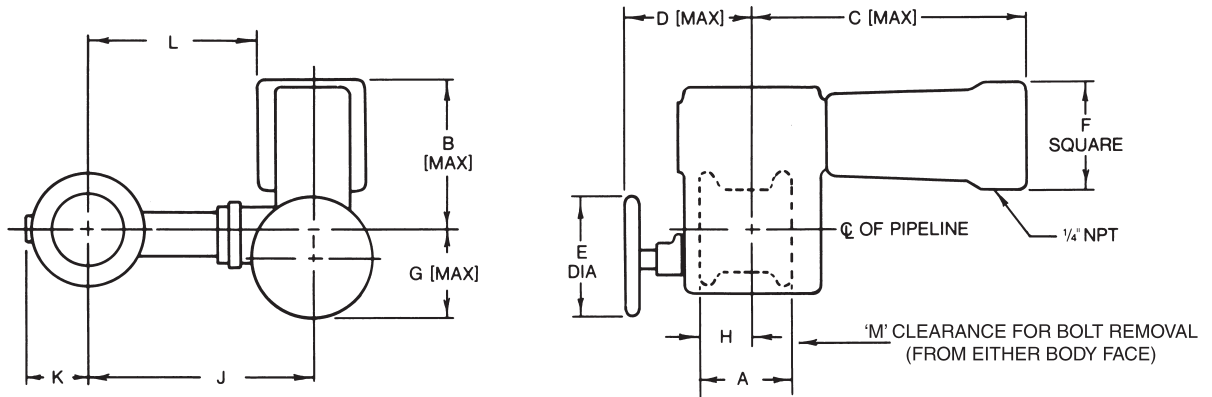

Dimensions (inches)

Valve size		A		B	C	D	E	F	G	H			J	K	L	M			
in.	DN	Threaded ends	Flanged and flangeless							Threaded ends	Flangeless	Flanged				Threaded ends	Flangeless	Flanged	ANSI Class 150 PN 10
1	25	4.00	4.00	6.8	11.5	8.4	6.3	5.5	4.4	2.64	2.64	2.01	8.1	1.5	5.4	6.5	9.0	9.0	9.0
1 1/2	40	5.39	4.50	6.9	11.5	8.4	6.3	5.5	4.4	3.31	2.44	2.32	9.2	2.0	6.5	6.5	10.0	10.0	10.0
2	50	5.75	4.88	6.9	11.5	8.4	6.3	5.5	4.5	3.31	2.44	2.44	9.4	2.6	6.7	10.5	10.5	10.5	10.5
3	80		6.50	10.3	16.8	8.9	6.3	6.9	5.1		3.82	3.39	13.1	3.3	9.6	11.8	13.5	14.0	14.0
4	100		7.62	10.4	16.8	8.9	6.3	6.9	5.2		4.17	4.17	14.0	4.3	10.5	13.0	14.0	16.0	16.5
6	150		9.00	13.0	20.4	12.0	10.0	8.6	8.4		5.00	5.00	17.0	5.8	12.7	15.5	16.0	18.5	18.5
8	200		9.56	13.1	20.4	12.0	10.0	8.6	8.5		5.83	5.83	18.5	8.0	14.2	15.5	18.5	19.5	21.0
10	250		11.69	13.2	20.4	12.0	10.0	8.6	8.6		6.57	6.57	22.6	9.9	18.3	20.0	20.5	22.5	24.5
12	300		13.31	13.3	20.4	12.0	10.0	8.6	8.7		7.24	7.24	24.0	10.9	19.7	20.0	22.5	24.8	25.5

Weight (lbs.)

Valve size		Actuator size	Flangeless		Flanged Class 150		Flanged Class 300		Flanged Class 600	
in.	DN		Kg	lbs.	Kg	lbs.	Kg	lbs.	Kg	lbs.
1	25	4.5"	17	38	18	41	20	45	20	45
1 1/2	40	4.5"	19	43	22	50	24	54	25	55
2	50	4.5"	20	45	24	54	27	60	28	63
3	80	6"	46	103	52	116	57	129	59	133
4	100	6"	54	121	65	146	73	165	86	133
6	150	7"	103	232	115	259	131	295	156	351
8	200	7"	122	274	140	314	161	363	197	442
10	250	7"	178	400	203	456	236	531		
12	300	7"	222	499	260	586	307	689		
6	150	No.9	131	295	143	321	159	358	184	414
8	200	No.9	150	337	168	377	189	426	225	505
10	250	No.9	206	463	231	519	264	594		
12	300	No.9	250	562	288	648	335	752		

Specific Dimensions (inches) for the No.9 Actuator

Valve size		B	C	D	E	F	G	L
in.	DN							
6	150	14.69	26.54	12.05	10.00	11.97	8.39	11.02
8	200	14.80	26.54	12.05	10.00	11.97	8.50	12.52
10	250	14.92	26.54	12.05	10.00	11.97	8.62	16.61
12	300	15.04	26.54	12.05	10.00	11.97	8.74	17.99

Dimensions and Weights

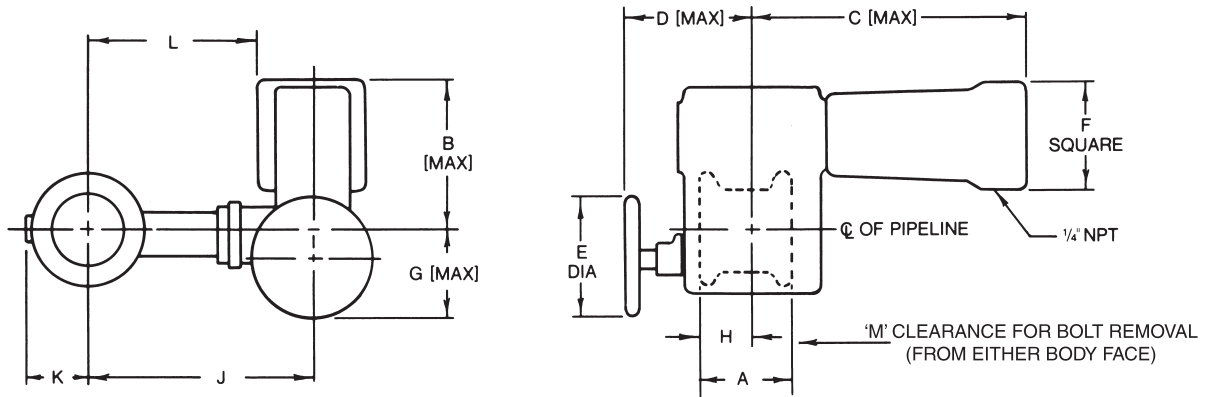

Dimensions (millimeters)

Valve size		A								H			J			M			
in.	DN	Threaded ends	Flanged and flangeless	B	C	D	E	F	G	Threaded ends	Flangeless	Flanged	J	K	L	ANSI Class 150 PN 10	ANSI Class 300 PN 16	ANSI Class 400 PN 26	ANSI Class 600 PN 40
1	25	102	102	173	293	213	160	140	112	67	67	51	206	38	137	165	229	229	229
1 1/2	40	137	114	175	293	213	160	140	113	84	62	59	234	51	165	165	254	254	254
2	50	146	124	176	293	213	160	140	115	84	62	62	239	66	170	267	267	267	267
3	80		165	262	426	226	160	175	130		97	86	333	84	244	300	343	356	356
4	100		194	264	426	226	160	175	131		106	106	356	109	267	330	356	406	419
6	150		229	330	517	306	254	218	213		127	127	432	147	323	394	406	470	470
8	200		243	333	517	306	254	218	216		148	148	470	203	361	394	470	495	533
10	250		297	335	517	306	254	218	219		167	167	574	251	465	508	521	572	622
12	300		338	338	517	306	254	218	222		184	184	610	277	500	508	572	630	648

Weight (Kg)

Valve size		Actuator size	Flangeless		Flanged Class 150		Flanged Class 300		Flanged Class 600	
in.	DN		Kg	lbs.	Kg	lbs.	Kg	lbs.	Kg	lbs.
1	25	4.5"	17	38	18	41	20	45	20	45
1 1/2	40	4.5"	19	43	22	50	24	54	25	55
2	50	4.5"	20	45	24	54	27	60	28	63
3	80	6"	46	103	52	116	57	129	59	133
4	100	6"	54	121	65	146	73	165	83	186
6	150	7"	103	232	115	259	131	295	156	351
8	200	7"	122	274	140	314	161	363	167	442
10	250	7"	178	400	203	456	236	531		
12	300	7"	222	499	260	586	307	689		
6	150	No.9	131	295	143	321	159	358	184	414
8	200	No.9	150	337	168	377	189	426	224	505
10	250	No.9	206	463	231	519	264	594		
12	300	No.9	250	562	288	648	335	752		

Specific Dimensions (millimeters) for the No.9 Actuator

Valve size		B	C	D	E	F	G	L
in.	DN							
6	150	373	674	306	254	304	213	280
8	200	376	674	306	254	304	216	318
10	250	379	674	306	254	304	219	422
12	300	382	674	306	254	304	222	457

Notes

Sales Office Locations

BELGIUM

Dresser Valves Europe
Boulevard du Souverain 207 B2
Vorstaan,
B-1160 Brussels, Belgium
Phone: +32-2-344-0970
Fax: +32-2-344-1123

BRAZIL

Dresser Industria e Comercio Ltda
Divisao Masoneilan
Rua Funchal, 129 - Conj. 5A
04551-060 - Sao Paulo - SP Brazil
Phone: 55-11-2146-3600
Fax: 55-11-2146-3610

CANADA

Ontario
Dresser - Masoneilan
DI Canada, Inc.
835 Harrington Court, 2nd Floor
Burlington, Ontario L7N 3P3,
Canada
Phone: 905-335-3529
Fax: 905-336-7628

CHINA

Dresser Flow Solutions,
Beijing Rep. Office
Suite 1703, Capital Mansion
6 Xinyuannan Rd. Chaoyang District
Beijing 100004, China
Phone: +86-10-8486-4515
Fax: +86-10-8486-5305

FRANCE

Masoneilan - Dresser
Produits Industriels
Energy 5
130/190 Boulevard de Verdun
92413 Courbevoie cedex, France
Phone: +33-1-4904-9000
Fax: +33-1-4904-9010

Dresser Produits Industriels S.A.S.,
Masoneilan
Customer Service Centre
55 rue de la Mouche,
Zone Industrielle
69540 Irigny, France
Phone: +33-4-72-39-06-29
Fax: +33-4-72-39-21-93

GERMANY

Dresser Valves Europe GmbH
Heiligenstrasse 75
Viersen D-41751, Germany
Phone: +49-2162-8170-0
Fax: +49-2162-8170-280

Dresser Valves Europe GmbH
Uhlandstrasse 58
60314 Frankfurt, Germany
Phone: +49-69-439350
Fax: +49-69-4970802

INDIA

Dresser Valve India Pvt. Ltd.
305/306, "Midas", Sahar Plaza
Mathurdas Vasanti Road
J.B. Nagar, Andheri East
Mumbai, 400059, India
Phone: +91-22-8354790
Fax: +91-22-8354791

Dresser Valve India Pvt. Ltd.
205, Mohta Building
4 Bhikaji Cama Place
New Delhi, 110 066, India
Phone: +91-11-2-6164175
Fax: +91-11-5-1659635

ITALY

Dresser Italia S.r.l.
Masoneilan Operations
Via Cassano, 77
80020 Casavatore, Napoli, Italy
Phone: +39-081-7892-111
Fax: +39-081-7892-208

JAPAN

Niigata Masoneilan Co. Ltd.
(NIMCO)
20th Floor, Marive East Tower
WBG 2-6 Nakase, Mihama-ku,
Chiba-shi, Chiba 261-7120 Japan
Phone: +81-43-297-9222
Fax: +81-43-299-1115

KOREA

Dresser Korea Inc.
2109 Kuk Dong Building 60-1
3-Ka, Choongmu-ro Chung-Ku
Seoul, Korea
Phone: +82-2-2274-0748
Fax: +82-2-2274-0720

KUWAIT

Dresser Flow Solutions
Middle East Operations
10th Floor, Al Rashed Complex
Fahad Salem Street, P.O. Box 242
Safat, 13003, Kuwait
Phone: +965-9061157
Fax: +965-3987879

MALAYSIA

Dresser Flow Solutions
Business Suite, 19A-9-1, Level 9
UOA Centre, No. 19, Jalan Pinang
50450 Kuala Lumpur, West Malaysia
Phone: +60-3-2161-0322
Fax: +60-3-2163-3612

MEXICO

Dresser Valve de Mexico,
S.A. de C.V.
Henry Ford No. 114, Esq. Fulton
Fraccionamiento Industrial
San Nicolas
54030 Tlalnepantla
Estado de Mexico
Phone: 52-5-310-9863
Fax: 52-5-310-5584

THE NETHERLANDS

Dresser Valves Europe
Steenhouwerstraat 11
3194 AG Hoogvliet,
The Netherlands
Phone: +31-10-438-4122
Fax: +31-10-438-4443

RUSSIA

DS Controls
Nekhinskaya Street, 61
Veliky Novgorod
Russia, 173021
Phone: +7-8162-15-7898
Fax: +7-8162-15-7921

SAUDI ARABIA

Dresser AL Rushaid
Valve & Instrument Co., Ltd.
(Darvico)
P.O. Box 10145
Jubail Industrial City 31961,
Saudi Arabia
Phone: +966-3-341-0278
Fax: +966-3-341-7624

SINGAPORE

Dresser Singapore Pte Ltd.
16 Tuas Avenue 8
Singapore 639231
Phone: +65-6-6861-6100
Fax: +65-6-6861-7172

SOUTH AFRICA

Dresser Limited
P.O. Box 2234
16 Edendale Road
Eastleigh, Edenvale 1610
Republic of South Africa
Phone: +27-11-452-1550
Fax: +27-11-452-6542

SPAIN

Masoneilan S.A.
C/Murcia 39 C
08830 Sant Boi de Llobregat
Barcelona, Spain
Phone: +34-93-652-6430
Fax: +34-93-652-6444

UNITED ARAB EMIRATES

Dresser Flow Solutions
Middle East Operations
P.O. Box 61302
Roundabout 8
Units JA01 & JA02
Jebel Ali Free Zone
Dubai, U. A. E.
Phone: +971-4-8838-752
Fax: +971-4-8838-038

UNITED KINGDOM

DI U.K. Ltd.
East Gillibrands
Skelmersdale,
Lancashire WN8 9TU, England
Phone: +44-1695-52600
Fax: +44-1695-52601

DI U.K. Ltd.

Unit 4, Suite 1.1, Nobel House
Grand Union Office Park
Packet Boat Lane
Uxbridge, Middlesex UB8 2GH
Phone: +44-1895-454-900
Fax: +44-1895-454-919

UNITED STATES

Dresser - Masoneilan
85 Bodwell Street
Avon, MA 02322-1190
Phone: 508-586-4600
Fax: 508-427-8971

Dresser - Masoneilan
4841 Leopard Street
Corpus Christi, TX 78408-2621
Phone: 361-877-2414
Fax: 361-584-1196

Dresser - Masoneilan

Dresser Direct
1250 Hall Court
Deer Park, TX 77536
Phone: 281-884-1000
Fax: 281-884-1010

Dresser Flow Solutions

(Contractor Sales)
16240 Port Northwest Drive
Houston, TX 77041
Phone: 832-590-2303
Fax: 832-590-2529

Dresser - Masoneilan

2950 East Birch Street
Brea, CA 92821
Phone: 714-572-1528
Fax: 714-572-1463



CF5000 SD - 03/06
35002 Series Camflex® II